

PRECISION 3 WAY DRILL PRESS VISE

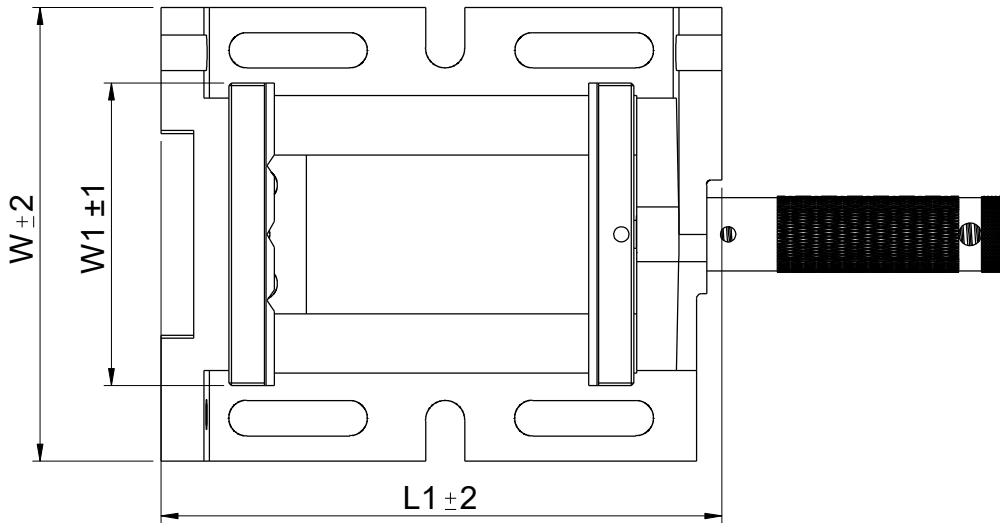
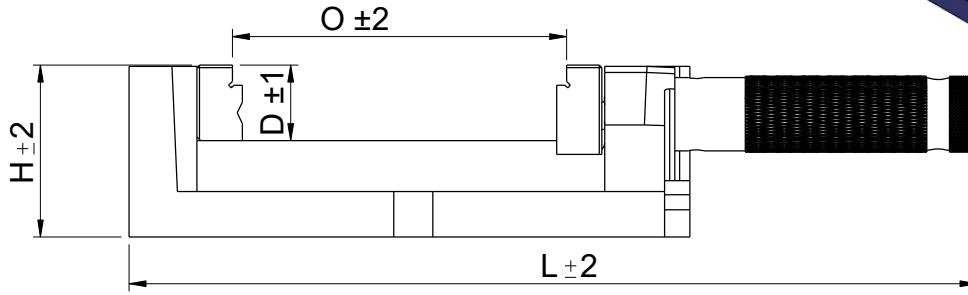
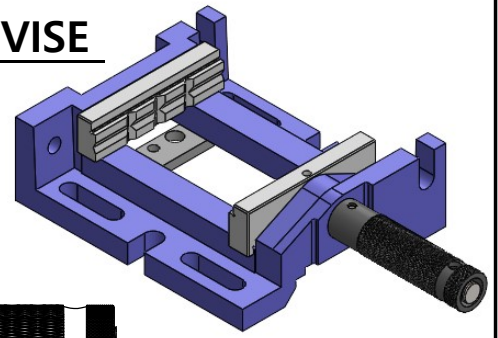

TECHNICAL DATA

ORDERING NO.	Length (L)		Width (W)		Height (H)		Jaw Width (W1)		Jaw Opening (O)		Jaw Depth (D)		Base Length (L1)	
	Inch	mm	Inch	mm	Inch	mm	Inch	mm	Inch	mm	Inch	mm	Inch	mm
110157	13.1/4"	338	7.1/8"	180	2.5/8"	67	4.3/4"	120	4.3/4"	120	1.1/8"	30	8.5/8"	221

SOBA® SHOBHA INDUSTRIES Pvt.Ltd.

CLIENT:

				TITLE:		PRECISION 3 WAY DRILL PRESS VISE					
				PART DESCRIPTION:							
				DWG NO.		110157		SCALE:		NTS	
				FILE NO:				PART NO:			
				REVISOR:				NAME:			
				DATE:				SIGN.			
				SHEET NO. 1 OF 1				SHEET FORMAT		A4	

This Drawing is the sole property of Shobha Industries Pvt. Ltd. It should not be copied or communicated to any without the written approval of the Director/Managers.

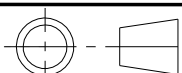

All Dimensions are in mm UNLESS OTHERWISE SPECIFIED.